

# Product data sheet

Specifications



## variable speed drive, Altivar Machine ATV320, 5.5kW, 380 to 500V, 3 phases, book

ATV320U55N4B

**Product availability: Stock - Normally stocked in distribution facility**

**Price\*: 1,032.00 USD**

### Main

Range of Product	Altivar Machine ATV320
Product or Component Type	Variable speed drive
Product Specific Application	Complex machines
Variant	Standard version
Format of the drive	Book
Mounting Mode	Wall mount
Communication Port Protocol	Modbus serial CANopen
Option card	communication module, CANopen communication module, EtherCAT communication module, Profibus DP V1 communication module, PROFINET communication module, Ethernet Powerlink communication module, EtherNet/IP communication module, DeviceNet
[Us] rated supply voltage	380...500 V - 15...10 %
nominal output current	14.3 A
Motor power kW	5.5 kW heavy duty
EMC filter	Class C2 EMC filter integrated
IP degree of protection	IP20

### Complementary

Discrete input number	7
Discrete input type	STO safe torque off, 24 V DC 1.5 kOhm DI1...DI6 logic inputs, 24 V DC 30 V) DI5 programmable as pulse input 0...30 kHz, 24 V DC 30 V)
Discrete input logic	Positive logic (source) Negative logic (sink)
Discrete output number	3
Discrete output type	Open collector DQ+ 0...1 kHz 30 V DC 100 mA Open collector DQ- 0...1 kHz 30 V DC 100 mA
Analogue input number	3
Analogue input type	AI1 voltage 0...10 V DC 30 kOhm 10 bits AI2 bipolar differential voltage +/- 10 V DC 30 kOhm 10 bits AI3 current 0...20 mA (or 4-20 mA, x-20 mA, 20-x mA or other patterns by configuration) 250 Ohm 10 bits
Analogue output number	1

Price is "List Price" and may be subject to a trade discount – check with your local distributor or retailer for actual price.

<b>Analogue output type</b>	Software-configurable current AQ1 0...20 mA 800 Ohm 10 bits Software-configurable voltage AQ1 0...10 V DC 470 Ohm 10 bits
<b>Relay output type</b>	Configurable relay logic R1A 1 NO 100000 cycles Configurable relay logic R1B 1 NC 100000 cycles Configurable relay logic R1C Configurable relay logic R2A 1 NO 100000 cycles Configurable relay logic R2C
<b>Maximum switching current</b>	Relay output R1A, R1B, R1C resistive, cos phi = 1 3 A 250 V AC Relay output R1A, R1B, R1C resistive, cos phi = 1 3 A 30 V DC Relay output R1A, R1B, R1C, R2A, R2C inductive, cos phi = 0.4 7 ms 2 A 250 V AC Relay output R1A, R1B, R1C, R2A, R2C inductive, cos phi = 0.4 7 ms 2 A 30 V DC Relay output R2A, R2C resistive, cos phi = 1 5 A 250 V AC Relay output R2A, R2C resistive, cos phi = 1 5 A 30 V DC
<b>Minimum switching current</b>	Relay output R1A, R1B, R1C, R2A, R2C 5 mA 24 V DC
<b>Method of access</b>	Slave CANopen
<b>4 quadrant operation possible</b>	True
<b>Asynchronous motor control profile</b>	Voltage/frequency ratio, 5 points Flux vector control without sensor, standard Voltage/frequency ratio - Energy Saving, quadratic U/f Flux vector control without sensor - Energy Saving Voltage/frequency ratio, 2 points
<b>Synchronous motor control profile</b>	Vector control without sensor
<b>Transient overtorque</b>	170...200 % of nominal motor torque
<b>Maximum output frequency</b>	0.599 kHz
<b>Acceleration and deceleration ramps</b>	Linear U S CUS Ramp switching Acceleration/deceleration ramp adaptation Acceleration/deceleration automatic stop with DC injection
<b>Motor slip compensation</b>	Automatic whatever the load Adjustable 0...300 % Not available in voltage/frequency ratio (2 or 5 points)
<b>Switching frequency</b>	2...16 kHz adjustable 4...16 kHz with derating factor
<b>Nominal switching frequency</b>	4 kHz
<b>Braking to standstill</b>	By DC injection
<b>Brake chopper integrated</b>	True
<b>Line current</b>	20.7 A 380 V heavy duty) 14.5 A 500 V heavy duty)
<b>Maximum Input Current per Phase</b>	20.7 A
<b>Maximum output voltage</b>	500 V
<b>Apparent power</b>	12.6 kVA 500 V heavy duty)
<b>Network Frequency</b>	50-60 Hz
<b>Relative symmetric network frequency tolerance</b>	5 %
<b>Prospective line Isc</b>	22 kA
<b>Base load current at high overload</b>	14.3 A
<b>Power dissipation in W</b>	Fan 195.0 W 380 V 4 kHz
<b>With safety function Safely Limited Speed (SLS)</b>	True
<b>With safety function Safe brake management (SBC/SBT)</b>	False
<b>With safety function Safe Operating Stop (SOS)</b>	False

With safety function Safe Position (SP)	False
With safety function Safe programmable logic	False
With safety function Safe Speed Monitor (SSM)	False
With safety function Safe Stop 1 (SS1)	True
With sft fct Safe Stop 2 (SS2)	False
With safety function Safe torque off (STO)	True
With safety function Safely Limited Position (SLP)	False
With safety function Safe Direction (SDI)	False
Protection type	Input phase breaks drive Overcurrent between output phases and earth drive Overheating protection drive Short-circuit between motor phases drive Thermal protection drive
Width	5.9 in (150 mm)
Height	12.1 in (308.0 mm)
Depth	9.1 in (232.0 mm)
Net Weight	9.7 lb(US) (4.4 kg)

## Environment

Operating position	Vertical +/- 10 degree
Product Certifications	CE ATEX NOM GOST EAC RCM KC
Marking	CE ATEX UL CSA EAC RCM
Standards	IEC 61800-5-1
Electromagnetic compatibility	Electrostatic discharge immunity test level 3 conforming to IEC 61000-4-2 Radiated radio-frequency electromagnetic field immunity test level 3 conforming to IEC 61000-4-3 Electrical fast transient/burst immunity test level 4 conforming to IEC 61000-4-4 1.2/50 $\mu$ s - 8/20 $\mu$ s surge immunity test level 3 conforming to IEC 61000-4-5 Conducted radio-frequency immunity test level 3 conforming to IEC 61000-4-6 Voltage dips and interruptions immunity test conforming to IEC 61000-4-11
Environmental class (during operation)	Class 3C3 according to IEC 60721-3-3 Class 3S2 according to IEC 60721-3-3
Maximum acceleration under shock impact (during operation)	150 m/s <sup>2</sup> at 11 ms
Maximum acceleration under vibrational stress (during operation)	10 m/s <sup>2</sup> at 13...200 Hz
Maximum deflection under vibratory load (during operation)	1.5 mm at 2...13 Hz
Permitted relative humidity (during operation)	Class 3K5 according to EN 60721-3
Volume of cooling air	15850.6 Gal/hr(US) (60 m <sup>3</sup> /h)
overvoltage category	III
Regulation loop	Adjustable PID regulator

<b>Speed accuracy</b>	+/- 10 % of nominal slip 0.2 Tn to Tn
<b>pollution degree</b>	2
<b>Ambient air transport temperature</b>	-13...158 °F (-25...70 °C)
<b>Ambient air temperature for operation</b>	14...122 °F (-10...50 °C) without derating 122...140 °F (50...60 °C) with derating factor
<b>Ambient Air Temperature for Storage</b>	-13...158 °F (-25...70 °C)

## Ordering and shipping details

<b>Category</b>	US1CP4B22152
<b>Discount Schedule</b>	CP4B
<b>GTIN</b>	3606480931291
<b>Returnability</b>	Yes
<b>Country of origin</b>	ID

## Packing Units

<b>Unit Type of Package 1</b>	PCE
<b>Number of Units in Package 1</b>	1
<b>Package 1 Height</b>	8.07 in (20.500 cm)
<b>Package 1 Width</b>	12.99 in (33.000 cm)
<b>Package 1 Length</b>	10.71 in (27.200 cm)
<b>Package 1 Weight</b>	12.150 lb(US) (5.511 kg)
<b>Unit Type of Package 2</b>	P06
<b>Number of Units in Package 2</b>	10
<b>Package 2 Height</b>	29.53 in (75.000 cm)
<b>Package 2 Width</b>	23.62 in (60.000 cm)
<b>Package 2 Length</b>	31.50 in (80.000 cm)
<b>Package 2 Weight</b>	150.157 lb(US) (68.110 kg)

## Environmental Data

Schneider Electric aims to achieve Net Zero status by 2050 through supply chain partnerships, lower impact materials, and circularity via our ongoing “Use Better, Use Longer, Use Again” campaign to extend product lifetimes and recyclability.

[Environmental Data explained >](#)

[How we assess product sustainability >](#)

### Environmental footprint

Carbon footprint (kg CO <sub>2</sub> eq, Total Life cycle)	<b>4939</b>
--	-------------

Environmental Disclosure	<a href="#">Product Environmental Profile</a>
--------------------------	---

## Use Better

### Materials and Substances

Packaging made with recycled cardboard	<b>No</b>
--	-----------

Packaging without single use plastic	<b>No</b>
--------------------------------------	-----------

EU RoHS Directive	<b>Pro-active compliance (Product out of EU RoHS legal scope)</b>
-------------------	---

SCIP Number	<b>A6762242-2cbd-4da8-8225-a61f2601cd85</b>
-------------	---

REACH Regulation	<a href="#">REACH Declaration</a>
------------------	-----------------------------------

China RoHS Regulation	<a href="#">China RoHS declaration</a>
-----------------------	--

California proposition 65

**WARNING:** This product can expose you to chemicals including: Lead and lead compounds, which is known to the State of California to cause cancer and birth defects or other reproductive harm. For more information go to [www.P65Warnings.ca.gov](http://www.P65Warnings.ca.gov)

### Energy efficiency

Product contributes to saved and avoided emissions

是

## Use Again

### Repack and remanufacture

Circularity Profile

[End of Life Information](#)

WEEE



The product must be disposed on European Union markets following specific waste collection and never end up in rubbish bins.

Take-back

No

Dimensions Drawings

**Dimensions**

---

**Right and Front View**

mm  
in.

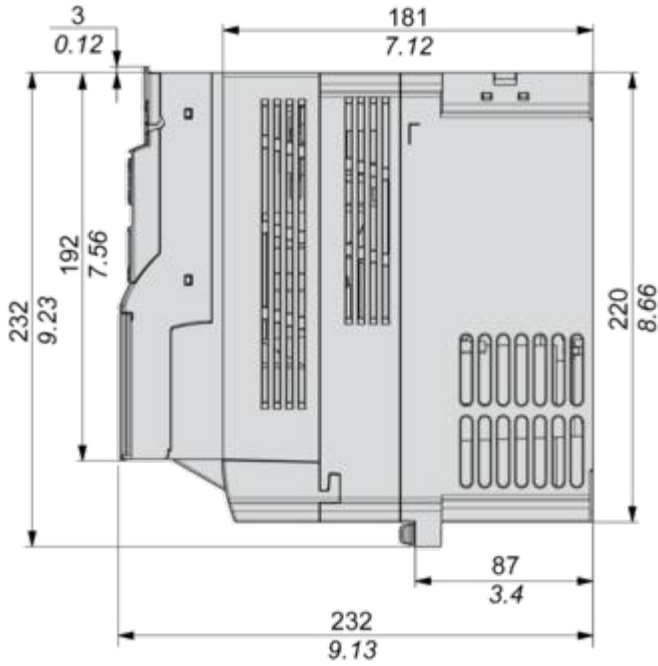

mm  
in.

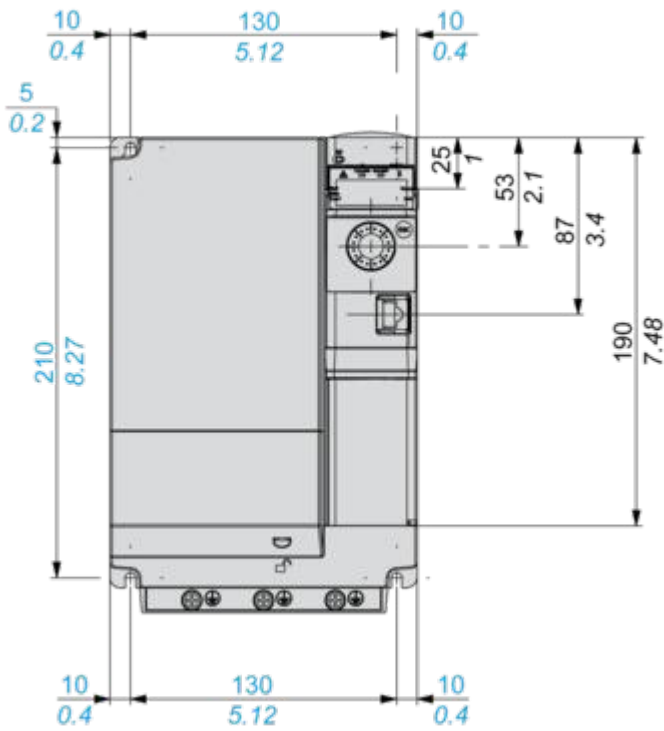

Right and Front View with EMC Plate



mm  
in.

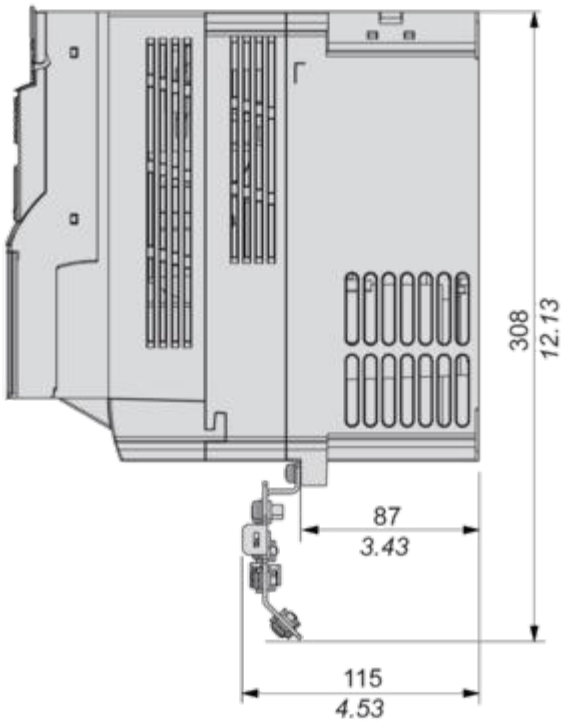

mm  
in.

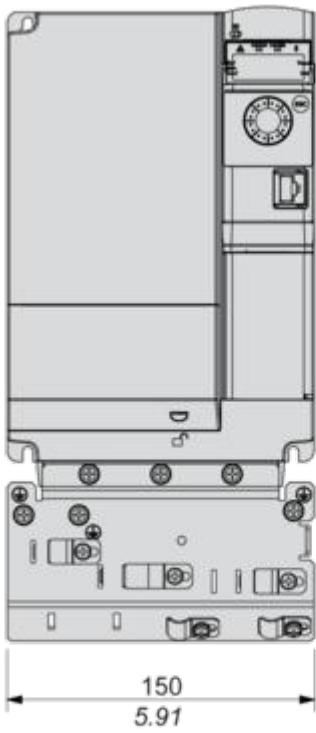

Mounting and Clearance

Mounting and Clearance

---

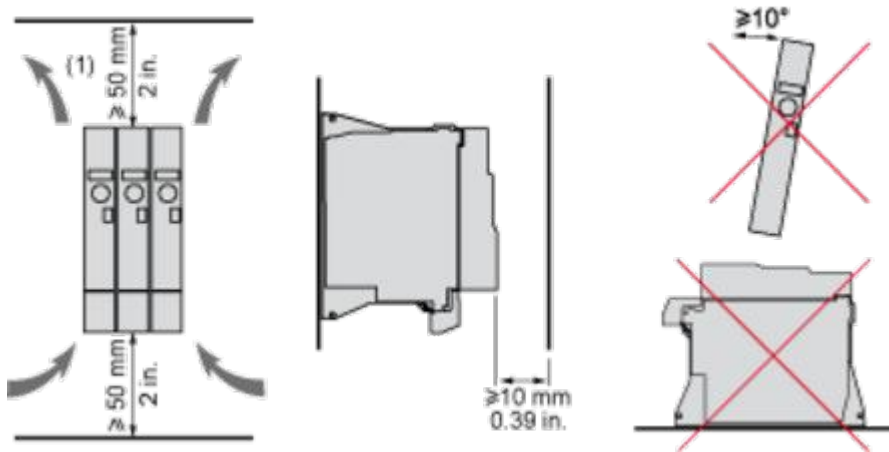

(1) Minimum value corresponding to thermal constraints.

Connections and Schema

Connection Diagrams

Diagram with Line Contactor

Connection diagrams conforming to standards ISO13849 category 1 and IEC/EN 61508 capacity SIL1, stopping category 0 in accordance with standard IEC/EN 60204-1.

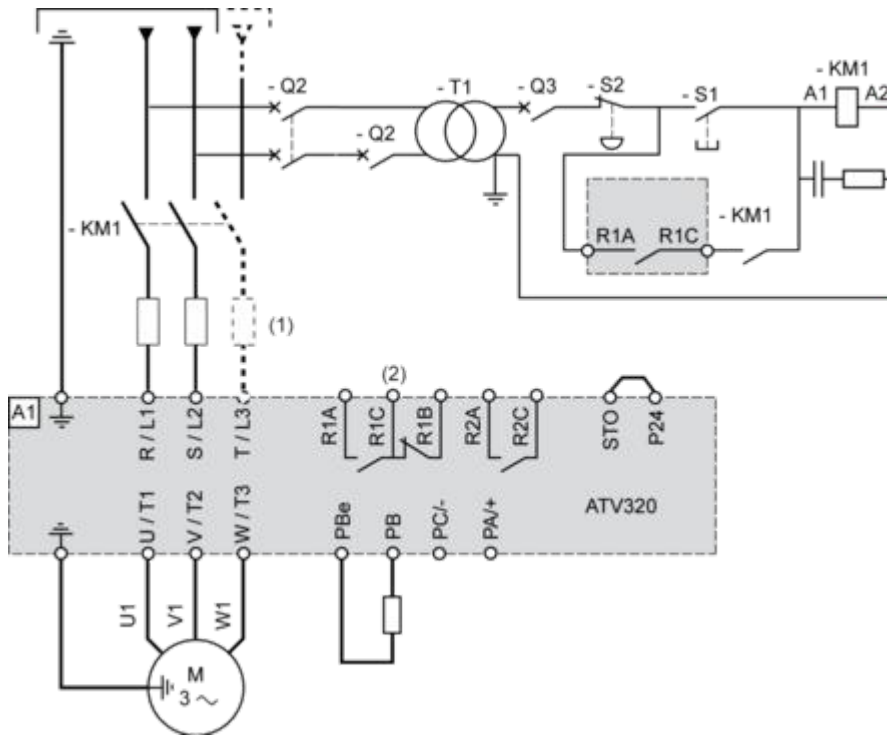

- (1) Line choke (if used)
- (2) Fault relay contacts, for remote signaling of drive status

Diagram with Switch Disconnect

Connection diagrams conforming to standards EN 954-1 category 1 and IEC/EN 61508 capacity SIL1, stopping category 0 in accordance with standard IEC/EN 60204-1.

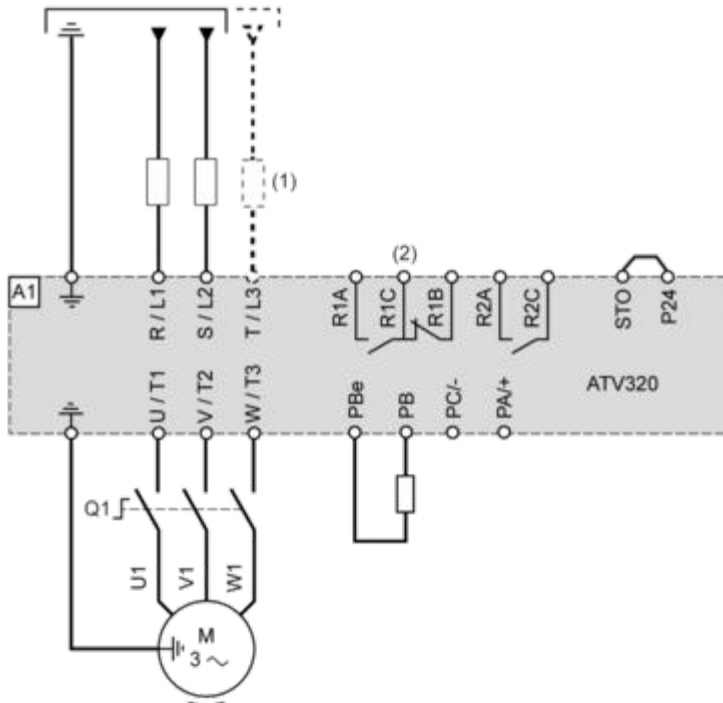

(1) Line choke (if used)

(2) Fault relay contacts, for remote signaling of drive status

Control Connection Diagram in Source Mode

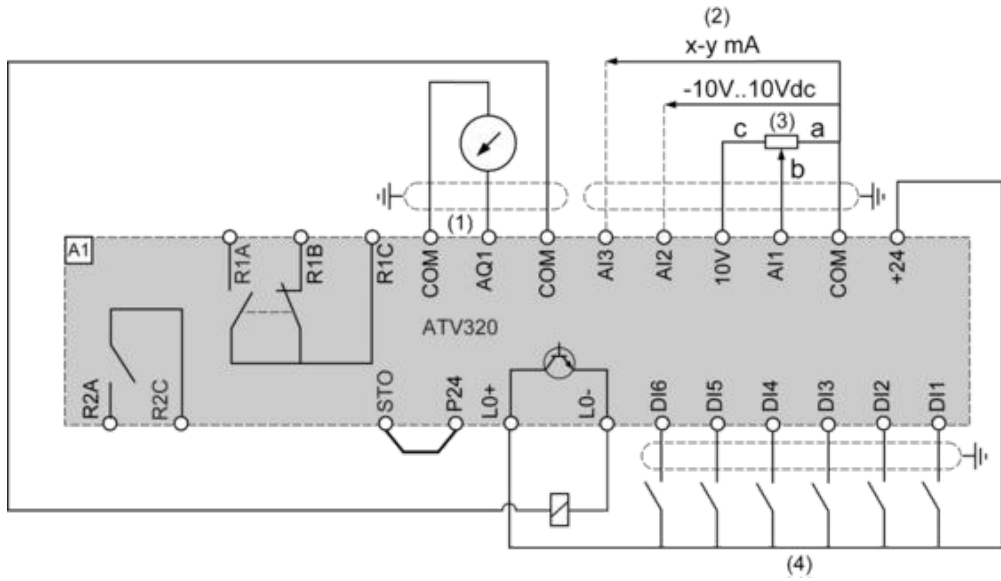

- (1) Analog output
- (2) Analog inputs
- (3) Reference potentiometer (10 kOhm maxi)
- (4) Digital inputs

Digital Inputs Wiring

The logic input switch (SW1) is used to adapt the operation of the logic inputs to the technology of the programmable controller outputs.

Switch SW1 set to "Source" position and use of the output power supply for the DIs.

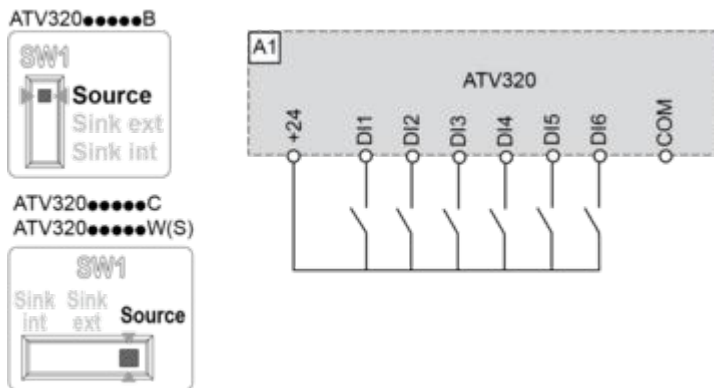

Switch SW1 set to "Source" position and use of an external power supply for the DIs.

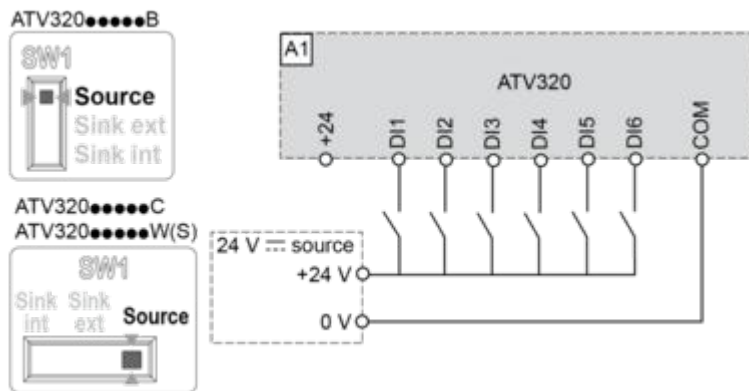

Switch SW1 set to "Sink Int" position and use of the output power supply for the DIs.

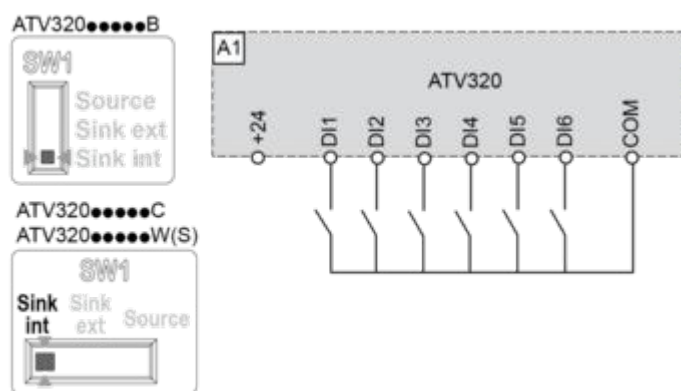

Switch SW1 set to "Sink Ext" position and use of an external power supply for the DIs.

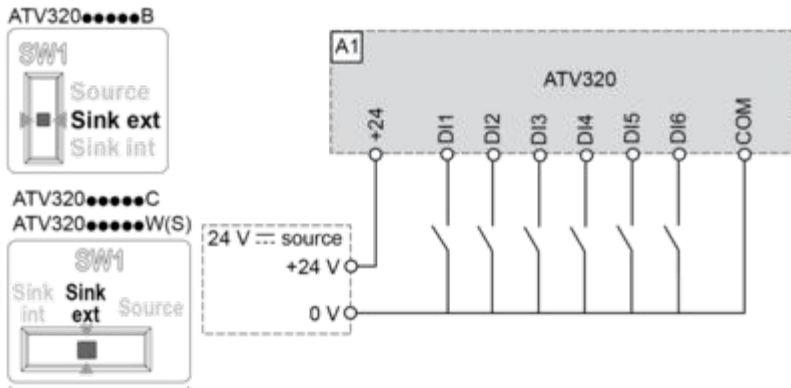

Performance Curves

**Derating Curves**

---

Derating curve for the nominal drive current ( $I_n$ ) as a function of temperature and switching frequency (SF).

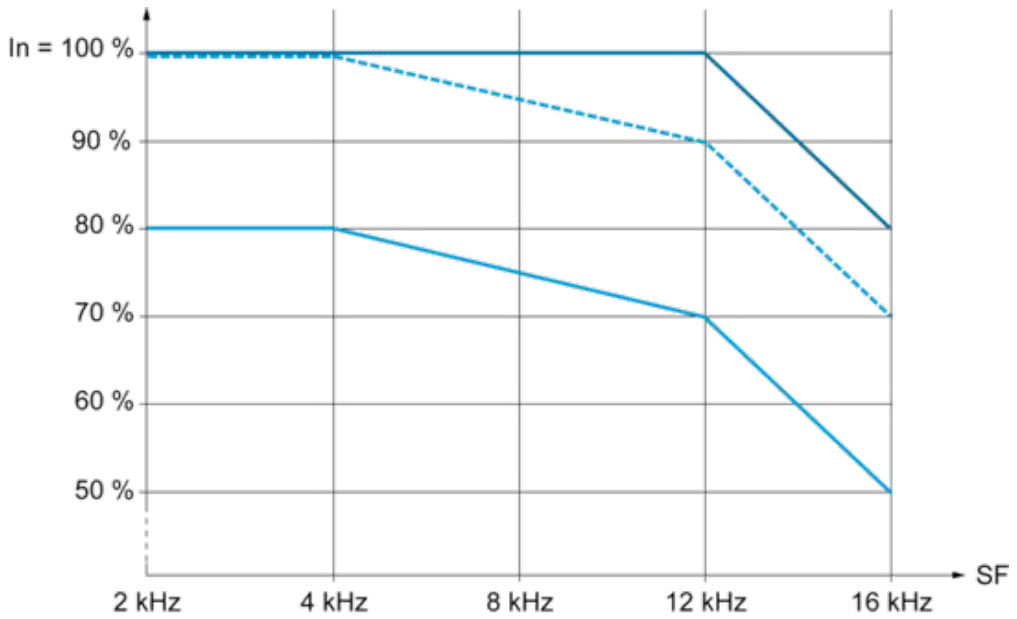

- 40 °C (104 °F) - Mounting type A, B and C
  - 50 °C (122 °F) - Mounting type A, B and C
  - 60 °C (140 °F) - Mounting type B and C
- $I_n$**  : Nominal Drive Current  
**SF** : Switching Frequency



Image of product / Alternate images

Alternative

---



